

Thank you for your purchase of this product.
Before using the watch, read this instruction manual carefully to ensure correct use.

Accessing the latest information (Cal. No.: YF05)

Be sure to visit the Citizen website at:
www.citizenwatch-global.com/

- Access also here to see notices.
- You can also see how to use enhanced features and functions such as slide rules and tachymeters on the web site. It depends on models whether they are equipped with enhanced features and functions or not.



Safety precautions — IMPORTANT

This manual contains instructions that should be strictly followed at all times not only for optimal use, but to prevent any injuries to yourself, other persons or property. We encourage you to read the entire booklet (especially, pages 13 and 14) and understand the meaning of the following symbols:

■ Safety advisories are categorized and depicted in this manual as follows:

	DANGER	Highly likely to cause death or serious injury
	WARNING	Can cause serious injury or death
	CAUTION	Can or will cause minor or moderate injury or damage

■ Important instructions are categorized and depicted in this manual as follows:
(Following symbols are examples of Pictograms.)

	Warning (caution) symbol followed by prohibited matters.
	Warning (caution) symbol followed by instructions that should be followed or precautions that should be observed.

Features



Connection with a smartphone through the dedicated app

Time and calendar are synchronized with those on the smartphone.
To get the dedicated app, access a download site of apps for your smartphone.

Built-in activity monitor

The watch records your activity and you can see its data on the dedicated app.

User-configurable buttons

You can assign three functions to the buttons of the watch as you want by setting them on the dedicated app.

- [TAKE A PHOTO]
- [MODE TOGGLE]
- [SECOND TIMEZONE]
- [DATE]
- [GOAL TRACKING]
- [NOTIFICATIONS]
- [MUSIC CONTROL]
- [RING PHONE]
- [VOLUME UP]
- [VOLUME DOWN]

CONTENTS

Safety precautions — IMPORTANT 1

Features 1

Before using this watch..... 2

 Band adjustment.....2

 Protective stickers2

Component identification 2

Before connecting with a smartphone..... 2

 Requirements for connection.....2

Execute pairing with the smartphone..... 2

 Executing pairing2

 When pairing fails3

 When connection fails after pairing (cancelling pairing).....4

Synchronizing your watch and smartphone 4

Adjustment of the time and calendar 4

Acceleration sensor 4

The screen of the dedicated app 5

 Side menu5

 [CHOOSE DEVICE] screen5

 [MY WATCH] screen5

 [WELLNESS] screen.....5

Changing settings of the dedicated app..... 6

 Changing goal values of activities.....6

Checking the status of the connected watch 7

Executing settings for functions and
 assigning them to the buttons of the watch 8

About the function hand (small hand) 8

Setting alarm 9

Setting notification10

 Checking and correcting the reference position.....11

Battery replacement.....12

Troubleshooting12

Bluetooth® wireless technology13

Water resistance13

Precautionary items and usage limitations13

Specifications14

Before using this watch

Band adjustment

We recommend seeking the assistance of an experienced watch technician for sizing of your watch. If adjustment is not done correctly, the bracelet may unexpectedly become detached leading to loss of your watch or injury (excluding products containing the band adjustment tool).

Consult an authorized service center. Other shops may charge for, or may not provide, the service.

Protective stickers

Be sure to remove any protective stickers that may be on your watch (case back, band, clasp, etc.). Otherwise, perspiration or moisture may enter the gaps between the protective stickers and the parts, which may result in a skin rash and/or corrosion of the metal parts.

Component identification

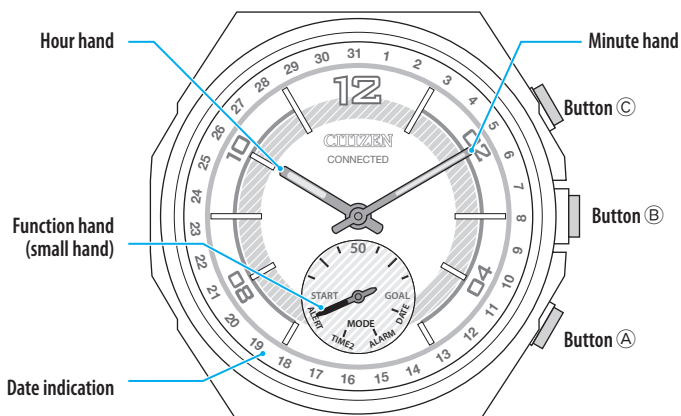

- The illustrations in this instruction manual may differ from the actual appearance of your watch.

Before connecting with a smartphone

You must install the dedicated app "CITIZEN CONNECTED" on your smartphone and start it to make pairing between the phone and the watch to connect them.

The flow of connection is as follows.

- This watch communicates with smartphones through Bluetooth® Low Energy power-saving communication technology.
- The Bluetooth® word mark and logos are registered trademarks owned by Bluetooth SIG, Inc.
- Google, Wear OS by Google, Google Play and Google Play logo, Google Fit, Google Assistant, Google Calendar, Gmail, Android and Android Go Edition, Android One, Google Pixel, Google Nest Learning Thermostat are trademarks of Google LLC.
- IOS® is a trademark or registered trademark of Cisco in the U.S. and other countries and is used under license.

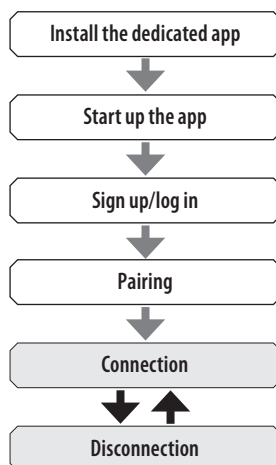

Requirements for connection

Android	Android OS 7.0 -
iPhone	iOS 15.0 -
Bluetooth®	Bluetooth smart compatible/ 4.2 Low Energy

- You cannot install the dedicated app when your smartphone is not compatible with it.
- Fulfillment of the requirements of your smartphone does not warrant normal operation of the app.
- Update of the dedicated app may be stopped after manufacturing of the watch is ended.

Actual screens and/or indication of the dedicated app may differ from those on this manual depending on your usage conditions and/or changes of specifications at update of the app.

In that case, follow instructions on the actual screen of the app.

Execute pairing with the smartphone

Execute pairing at first when connecting the watch and your smartphone.

- Unique pairing information is saved on the watch and smartphone as pairing is executed.
- Make an account at the startup of the dedicated app. An e-mail address which can be used for e-mail reception is required for making an account.
- Keep the mail address and password for the account in case they are required.

Executing pairing

- For pairing, you have to operate both the watch and the smartphone.
- Charge the smartphone sufficiently beforehand.
- Turn on functions related with Bluetooth® and location information on your smartphone.

- Download the dedicated app "CITIZEN CONNECTED" at an app site and install it.



- Start the dedicated app.

- Keep the app screen displayed until pairing is finished.

- Tap [HYBRID].

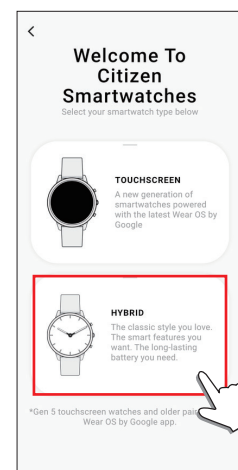

4 Make an account.

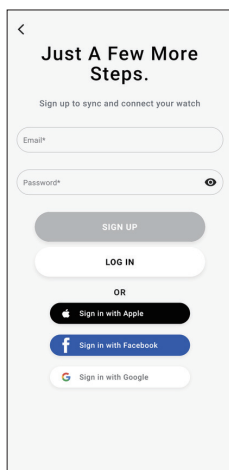

- Proceed to authentication process when you made an account. An authentication number will be sent to the mail address you entered here.
- Tap [LOG IN] if you had logged out without executing pairing after making an account before.
- Once signed up, the status (login status) is kept regardless whether the app is activated or deactivated.

5 Press the right middle button (B) and tap [CONTINUE] on the screen of the app as the [Start Pairing] screen is shown.

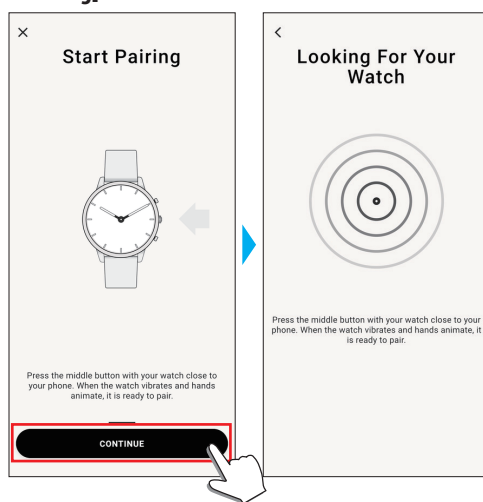

6 Tap [THIS IS MY WATCH].

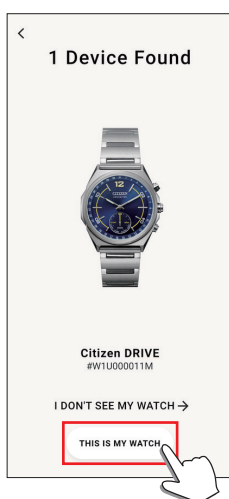

- The watch displayed on the screen may look different from the actual one you use.
- Tap [I DON'T SEE MY WATCH] when not only its color but whole appearance looks different from yours.
- When update of the watch has started, wait until it is finished.

7 Press and hold the upper right button (C) of the watch within time limit.



Pairing starts.

To start pairing on the screen of the app

Tap the watch icon (C) on the upper right of the home screen, swipe left on the [CHOOSE DEVICE] screen and tap [ADD NEW WATCH].

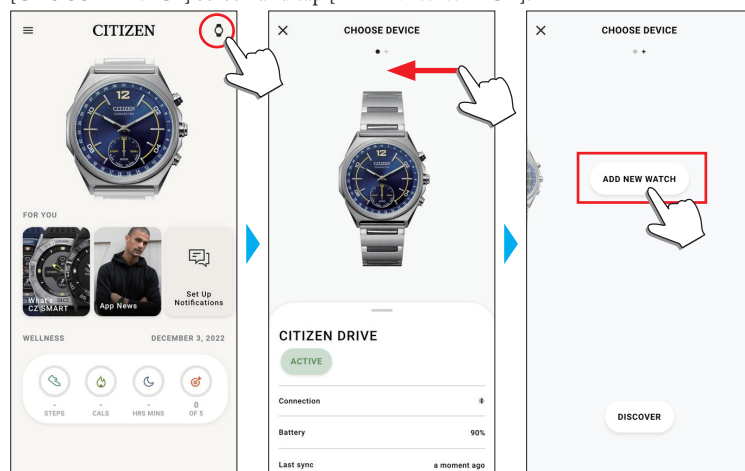

When pairing fails

When pairing fails and the target watch does not appear on the dedicated app, try pairing again following the steps below.

- 1 Remove "Citizen Connected HR" on Bluetooth® setting of your smartphone.
- 2 Turn off the Bluetooth function on your smartphone and turn it on again.
- 3 Execute pairing between the watch and the smartphone again.

When connection fails after pairing (cancelling pairing)

Try pairing again following the steps below.

- 1 Tap the watch icon (📱) on the upper right of the home screen.
- 2 Swipe left or right on the [CHOOSE DEVICE] screen to display the watch with which you want to connect your smartphone.
- 3 Swipe up the bottom tab on the [CHOOSE DEVICE] screen to display the menu.

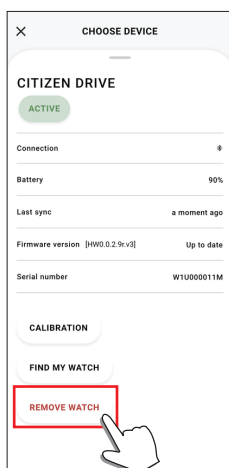

- 4 Tap [REMOVE WATCH].
- 5 Remove "Citizen Connected HR" on Bluetooth® setting of your smartphone.
- 6 Turn off the Bluetooth function on your smartphone and turn it on again.
- 7 Execute pairing between the watch and the smartphone again.

Synchronizing your watch and smartphone

After pairing, the watch and your smartphone are connected and synchronized automatically as the dedicated app is started up or displayed on the phone.

- All the hands of the watch turn fully around when synchronization starts.
- The time and calendar on the watch are also synchronized with those on the smartphone.
- It may take a certain period of time for data synchronization.
- Some operations of the app such as change of settings are accompanied with data synchronization.
- Synchronization does not start if distance between the smartphone and the watch is 10 m (30 feet) or more or there is any obstacle between them.

Swiping down the home screen also starts data synchronization.

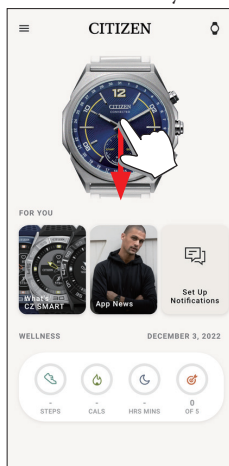

Adjustment of the time and calendar

This watch receives time information from your smartphone at every connection and adjusts the time and calendar automatically.

- You cannot adjust time and calendar on the watch only by itself.

Acceleration sensor

This watch is equipped with a built-in acceleration sensor. It always measures your activities while you wear the watch.

On the [WELLNESS] screen of the dedicated app, activity data are shown in graphs as daily/weekly/monthly records.

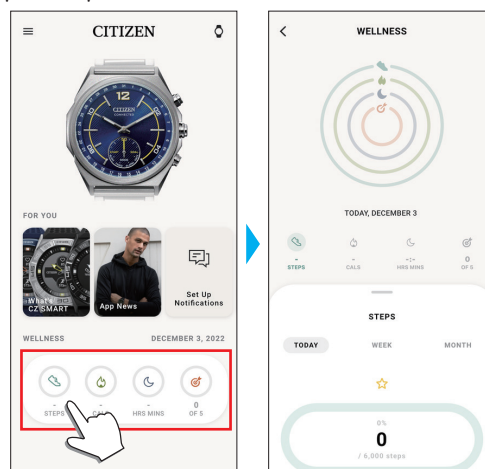

In addition, on the screen of dedicated app, you can check calorie consumption derived from your height and weight, sleep time, etc.

- When you achieve the activity goal you set on the dedicated app, the watch vibrates to notify the achievement.
 - Activity data recorded in the watch is transferred to the dedicated app when the watch and the smartphone are synchronized and it is stored in the app.
 - Up to about 40-day data of activity is saved on the watch.
 - Data gathered with this product can be sent to other apps and browsed.
 - This product interprets actual movement of the watch detected through its acceleration sensor with its special way to figure out your activities such as your steps or sleep.
- It is a kind of estimation and its results may differ from actual activities.
- You cannot edit data. You cannot also display activity data collected through other devices on the dedicated app of this watch.

The screen of the dedicated app

We call the screen just below the home screen, which appears immediately after starting the dedicated app.

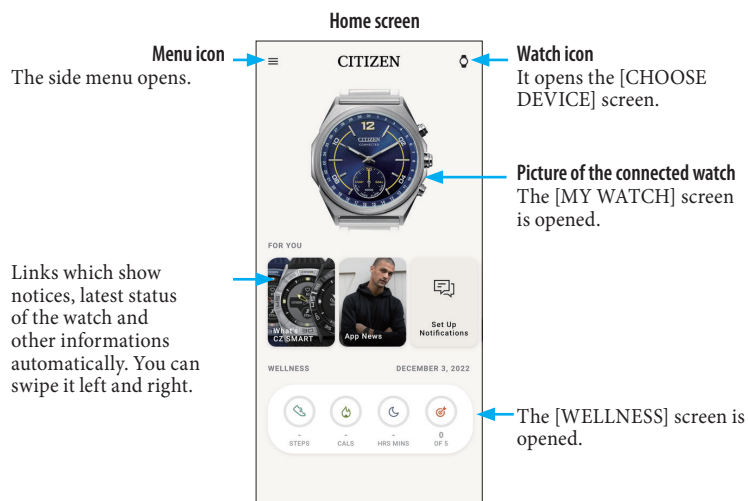

Side menu

You can control your account, settings of activity goals and those for the dedicated app here.

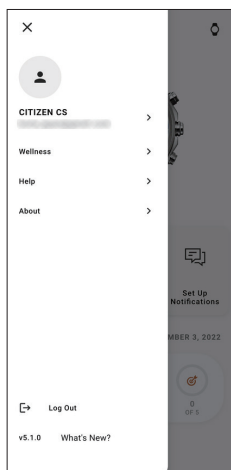

[CHOOSE DEVICE] screen

You can add watches, manage connection and adjust the reference position of the watch hands here.

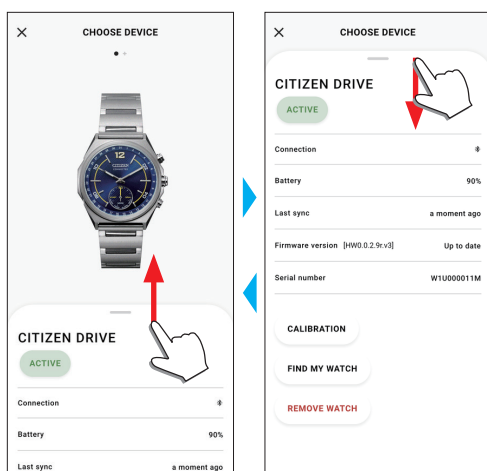

[MY WATCH] screen

You can assign various functions to the buttons of the watch. You can also control settings of notifications and alarm.

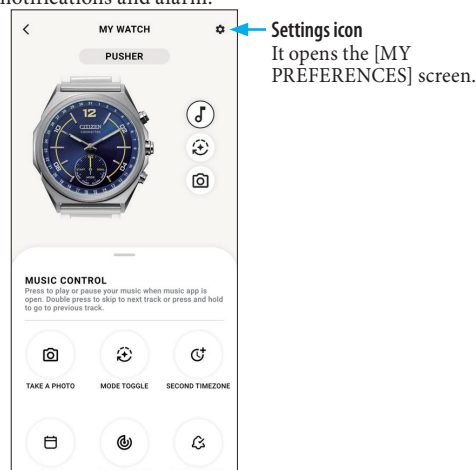

[MY PREFERENCES] screen

You can control settings of alarm, notifications, unit, etc. here.

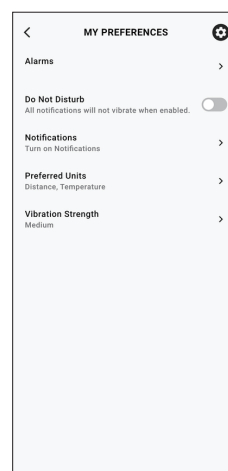

[WELLNESS] screen

It is the screen for indicating the data of the activity monitor on the watch. The screen has the four following sub menus: [STEPS], [ACTIVE CALORIES (CAL)], [SLEEP (HRS MINS)] and [GOAL TRACKING].

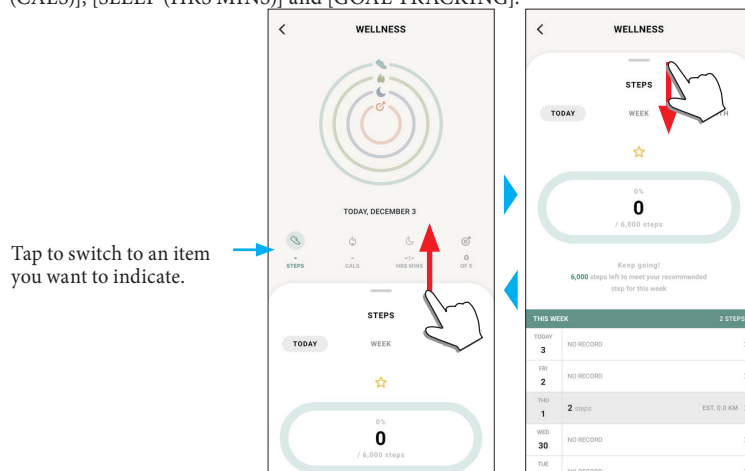

Tap to switch to an item you want to indicate.

- Activity amount is indicated by percentage where the target value set is supposed 100 %. One whole circle means 100 % on a circle graph. For bar graphs, the 100 % line is indicated in the graph field.
- For details of Target value, see "Changing goal values of activities" (→ page 6).

Changing settings of the dedicated app

1 Start the dedicated app.

The watch and the smartphone are connected.

- If you have not signed up, sign up.
- If synchronization of the watch and the smartphone starts, wait until it is finished.

2 Tap the menu icon (≡) on the upper left of the home screen.

The side menu opens.

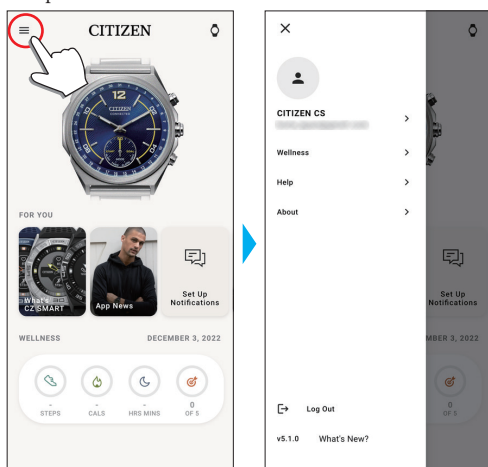

Account name	Tap the name to change account name and password.
[Wellness]	You can change connected apps, height, weight, gender and settings of activity goals here.
[Help]	You can access FAQ and contact us here.
[About]	You can control data sharing setting for software improvement and browse terms of use and privacy policy here. You can also remove your account here.
[Log Out]	Use this to log out of the dedicated app. Your account is not removed.
Version indication	Version of this dedicated app is indicated.
[What's New?]	You can access the latest information of this dedicated app and other topics.

Changing goal values of activities

1 Start the dedicated app.

The watch and the smartphone are connected.

- If you have not signed up, sign up.
- If synchronization of the watch and the smartphone starts, wait until it is finished.

2 Tap the menu icon (≡) on the upper left of the home screen, then tap [Wellness] on the side menu.

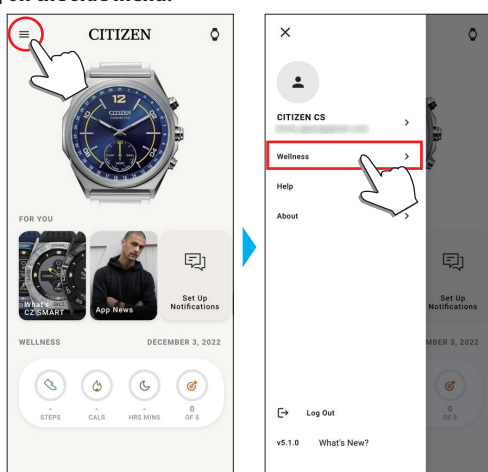

The [WELLNESS] screen is opened.

3 Tap [Set Goals] on the [WELLNESS] screen.

The [SET GOALS] screen is opened.

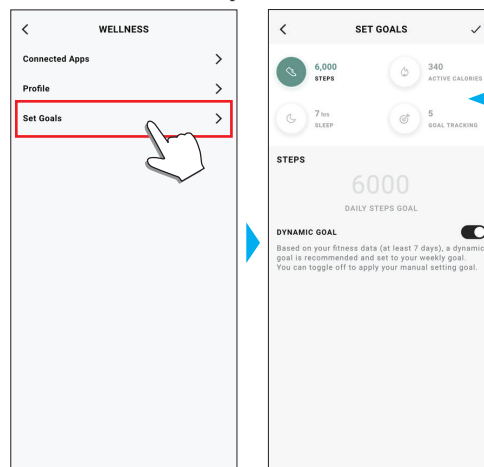

The current setting values are indicated. Tap an item whose setting value you want to change.

4 Choose the item which you want to change goal value on the top of the screen and tap the value.

The screen keyboard appears.

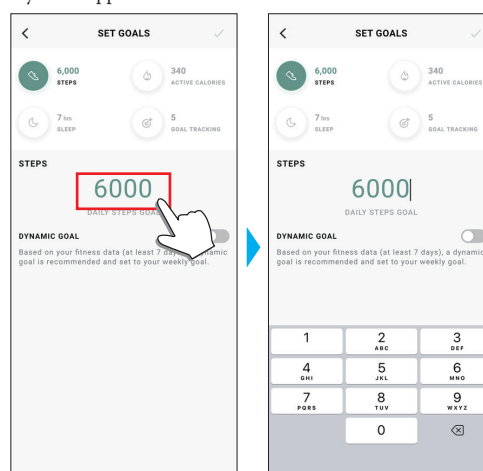

- When [DYNAMIC GOAL] is active on [STEPS], you cannot change its goal value. The goal value is automatically set based on your past activity history (at least records of your 7-day activity is required to activate the function).

5 Tap the check icon (✓) on the upper right of the [SET GOALS] screen to finish the procedure.



Checking the status of the connected watch

1 Start the dedicated app.

The watch and the smartphone are connected.

- If you have not signed up, sign up.
- If synchronization of the watch and the smartphone starts, wait until it is finished.

2 Tap the watch icon (🕒) on the upper right of the home screen.

The [CHOOSE DEVICE] screen is opened.

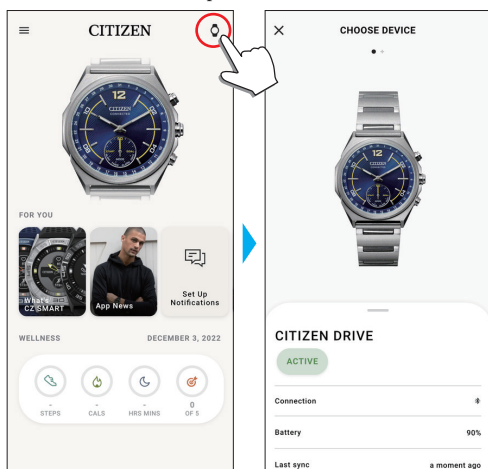

3 Swipe left or right on the screen to display the connected watch and swipe up the tab on the bottom of the screen.

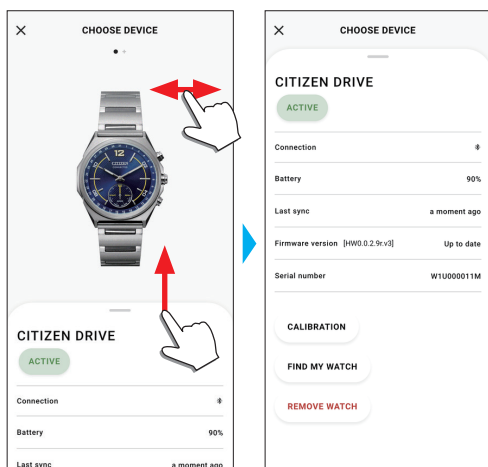

[ACTIVE]	[ACTIVE] is indicated for the currently connected watch. • When you use two or more watches, you can switch the watch to be connected by tapping [MAKE ACTIVE].
[Connection]	The current connection status is indicated. 📶: Connected 📶: Disconnected
[Battery]	You can check battery remaining of the connected watch here.
[Last sync]	The time elapsed since the last connection is indicated.
[Firmware version]	The current firmware version of the watch is indicated.
[Serial number]	The serial number of the watch is indicated.
[CALIBRATION]	Check and correct the reference position of the hands. For details, see "Checking and correcting the reference position" (→ page 11).
[FIND MY WATCH]	Use this to search the watch. A rough-estimated position of the watch where it lastly synchronized with the smartwatch can be indicated on the map. • Permission for access to the positional information of your smartphone is needed.
[REMOVE WATCH]	Use this to cancel pairing between the watch and the smartphone and reset the watch. • Keep the watch and the smartphone within connectible distance.

Executing settings for functions and assigning them to the buttons of the watch

You can assign functions you like to the buttons of the watch. Some functions need settings on the dedicated app.

1 Start the dedicated app.

The watch and the smartphone are connected.

- If you have not signed up, sign up.
- If synchronization of the watch and the smartphone starts, wait until it is finished.

2 Tap the picture of the connected watch on the home screen.

The [MY WATCH] screen is opened.

The function list is appeared on the tab on the bottom of the screen.

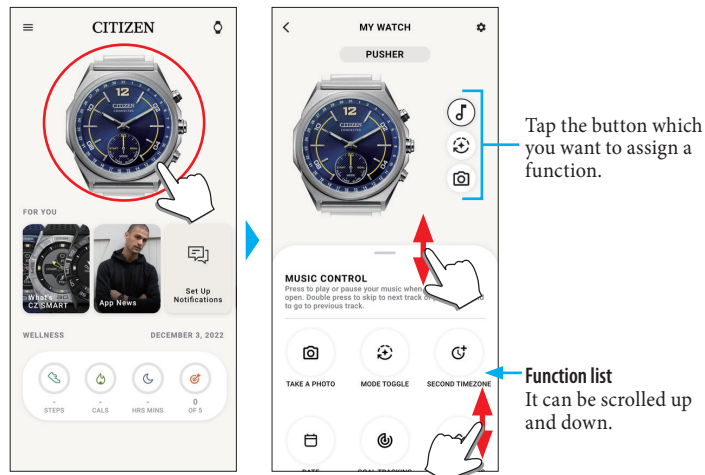

- The example above shows when the upper right button © is tapped.

3 Tap the button which you want to assign a function to and tap a function on the bottom of the screen.

[TAKE A PHOTO]	Pressing the button while using the photo app takes a picture.
[MODE TOGGLE]	Each time you press the button, the indication of the watch switches in the following order: notification (ALERT), 2nd time zone (TIME2), alarm time (ALARM), date indication (DATE). Indication of the function hand (small hand) changes corresponding to the switch of the indication above.
[SECOND TIMEZONE]	Pressing the button indicates the 2nd time zone on the watch. Set an area you want to indicate when assigning the function. The function hand (small hand) points TIME2 .
[DATE]	Pressing the button indicates the current date with the hour and minute hands. The function hand (small hand) points DATE .
[GOAL TRACKING]	The watch records when you pressed the button and number of times you pressed it.
[NOTIFICATIONS]	Pressing the button indicates the last indication received with the hour and minute hands. The function hand (small hand) points ALERT .
[MUSIC CONTROL]	You can control music playback through the watch while using the music app: can command play/pause/go previous/go next. Play/pause: Press and release the button once. Back to the previous tune: Press and hold the button during playback. Go forward to the next tune: Press and release the button twice during playback
[RING PHONE]	Pressing the button makes the smartphone emitting sound. You can set the sound you like. To stop the sound, press the same button again.
[VOLUME UP]	Pressing the button turns up the volume.
[VOLUME DOWN]	Pressing the button turns down the volume.

4 Tap the back icon (<) on the upper right of the [MY WATCH] screen to finish the procedure.

- Follow instructions on the screen.



The selected function is assigned to the button.

About the function hand (small hand)

■ Achievement level indication of steps

The function hand (small hand) of this watch normally indicates daily achievement level of steps measured with the activity monitor of the watch.

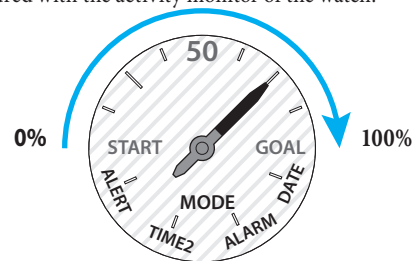

- The example above shows 75 % achievement level.
- The achievement level is reset at 0:00 every day and the indication returns to 0 %.

■ Mode indication

When some functions have been assigned to the buttons of the watch and one of the following functions is activated, indication of the watch is changed for 10 seconds and the function hand (small hand) points the mode corresponding to the activated function.

Indication of the function hand (small hand)		Indication of the hour and minute hands
	ALERT	The previous notification is indicated. Nothing is indicated when no notification exists.
	TIME2	It indicates the time of the place you chose on [SECOND TIMEZONE].
	ALARM	The alarm time set on [Alarms] is indicated.
	DATE	Date is indicated.

- **ALERT**, **TIME2** and **DATE** are indicated when any of [NOTIFICATIONS], [SECOND TIMEZONE] or [DATE] are assigned to buttons of the watch and a corresponding one is pressed. They are also indicated when using a watch button which is assigned the [MODE TOGGLE] function.
- **ALARM** is indicated by pressing a watch button which is assigned the [MODE TOGGLE] function repeatedly. **ALARM** is skipped when alarm is not set.

Setting alarm

1 Start the dedicated app.

The watch and the smartphone are connected.

- If you have not signed up, sign up.
- If synchronization of the watch and the smartphone starts, wait until it is finished.

2 Tap the picture of the connected watch on the home screen.

The [MY WATCH] screen is opened.

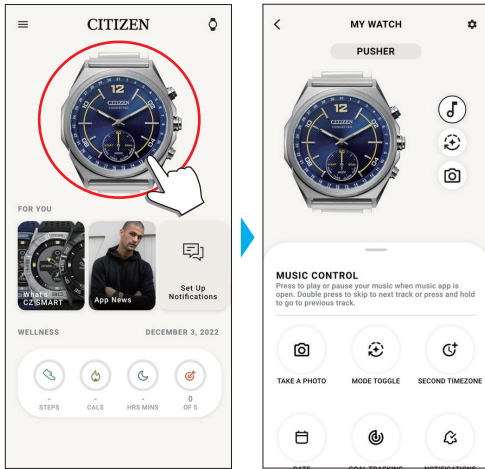

3 Tap the setting icon (⚙️) on the [MY WATCH] screen.

The [MY PREFERENCES] screen is opened.

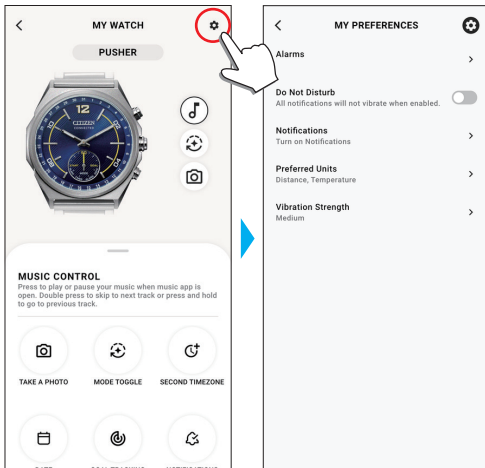

4 Tap [Alarms] on the [MY PREFERENCES] screen.

The [ALARMS] screen is opened.

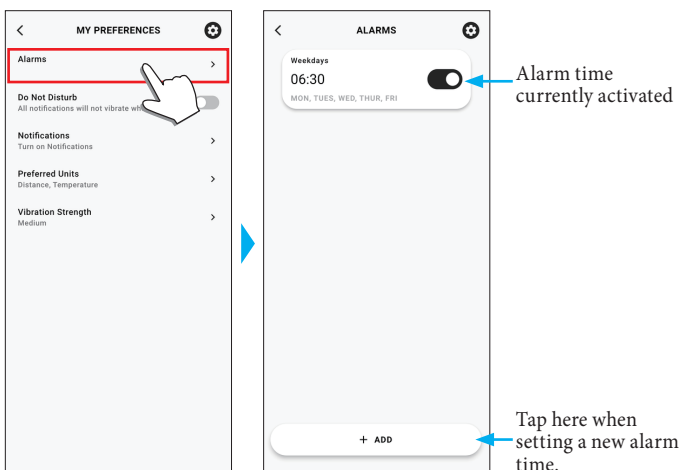

5 Tap [+ ADD] on the bottom of the [ALARMS] screen.

The [ADD ALARM] screen is opened.

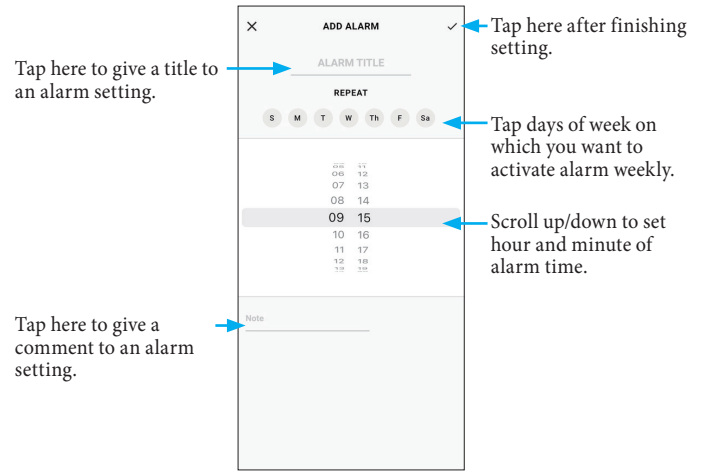

- Tap days of week on [REPEAT] on which you want to use alarm repeatedly. On the example below, Monday - Friday are selected.



6 After finishing setting of alarm time, tap the check icon (✓) on the upper right of the [ADD ALARM] screen to finish the procedure.



The alarm time newly set is indicated in the activated status.

■ When alarm time comes

The hour and minute hands jitter and the watch vibrates.

- The function hand (small hand) points **ALARM**.
- Press any button to stop alarm.

■ Turning on/off the alarm

Tap the switch of alarm setting to turn on/off on the [ALARMS] screen.

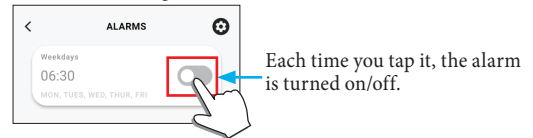

■ Changing alarm setting

Tap alarm setting on the [ALARMS] screen to open the [EDIT ALARM] screen.

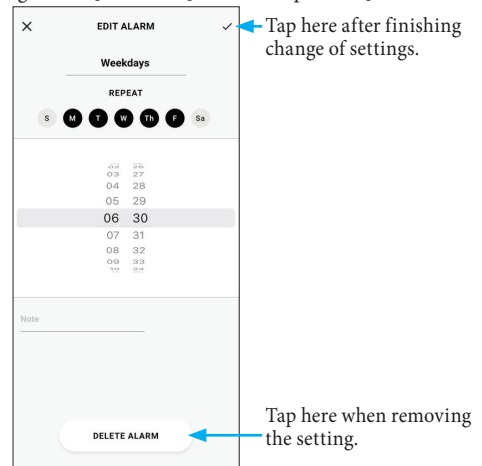

Setting notification

The watch shows notifications by moving the minute and hour hands to the positions previously set corresponding to types of notifications. The watch vibrates when telling a notification.

- Notifications may not be received if distance between the smartphone and the watch is 10 m (30 feet) or more or there is any obstacle between them.
- Number of vibration times affects battery life of the watch.

1 Start the dedicated app.

The watch and the smartphone are connected.

- If you have not signed up, sign up.
- If synchronization of the watch and the smartphone starts, wait until it is finished.

2 Tap the picture of the connected watch on the home screen.

The [MY WATCH] screen is opened.

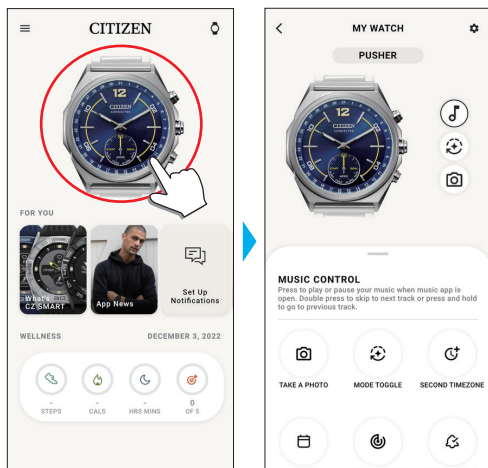

3 Tap the setting icon (⚙️) on the [MY WATCH] screen.

The [MY PREFERENCES] screen is opened.

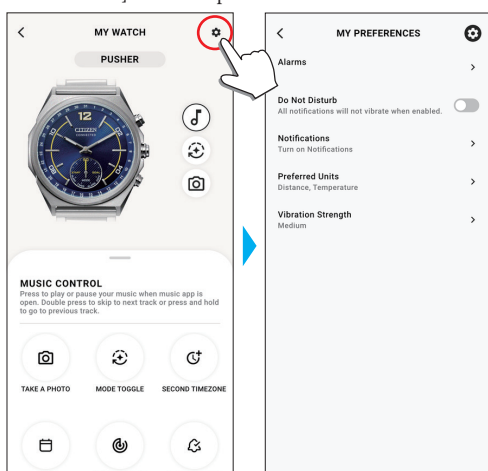

4 Tap [Notifications] on the [MY PREFERENCES] screen.

The [NOTIFICATIONS] screen is opened.

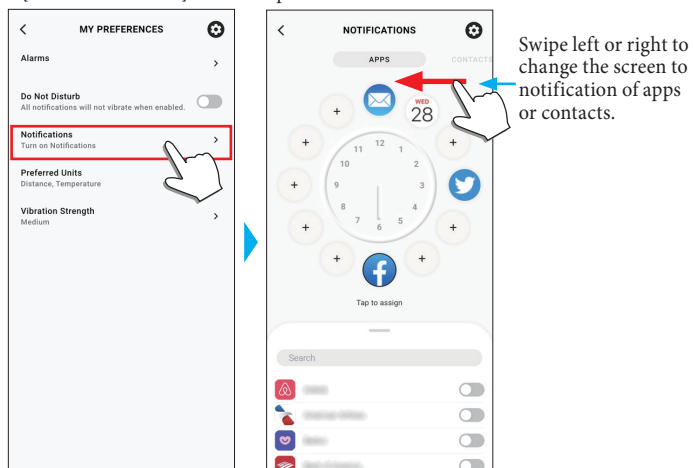

5 Tap a notification indicating position and swipe up the tab on the bottom of the screen.

A list of apps or a list of contacts appears.

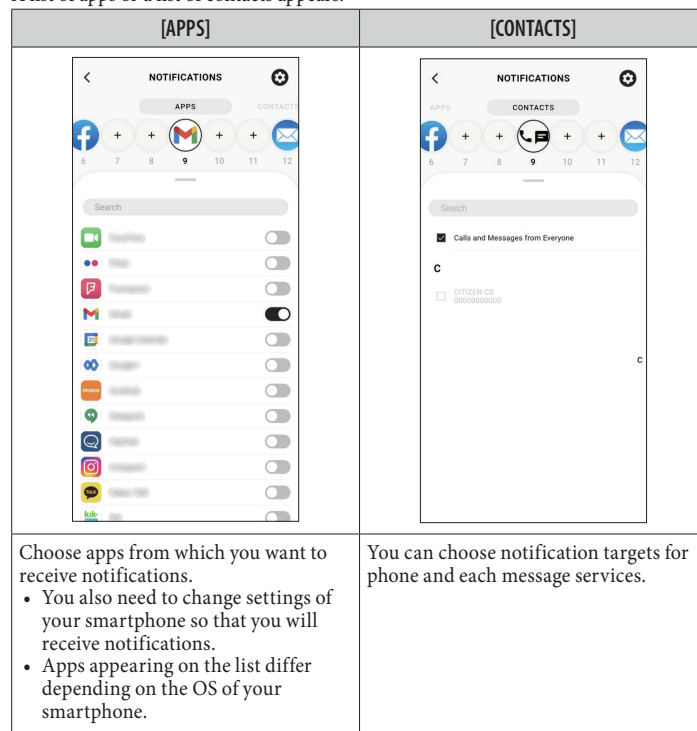

- Access right setting is required when accessing an address management app on your smartphone.

On Android OS, you can tap items with “!” and control their access right.

■ Changing vibration strength setting

Use [Vibration Strength] on the [MY PREFERENCES] screen.

■ To stop notifications

Turn on/off the switch of [Do Not Disturb] of the [MY PREFERENCES] screen.

Checking and correcting the reference position

Check and adjust the reference position through the dedicated app.

If the time or calendar is not shown correctly even after connecting with the smartphone, check whether the reference position of the watch hands is correct.

- If the hands do not reflect the correct reference position, the time will not be indicated accurately.

1 Start the dedicated app.

The watch and the smartphone are connected.

- If you have not signed up, sign up.
- If synchronization of the watch and the smartphone starts, wait until it is finished.

2 Tap the watch icon (🕒) on the upper right of the home screen.

The [CHOOSE DEVICE] screen is opened.

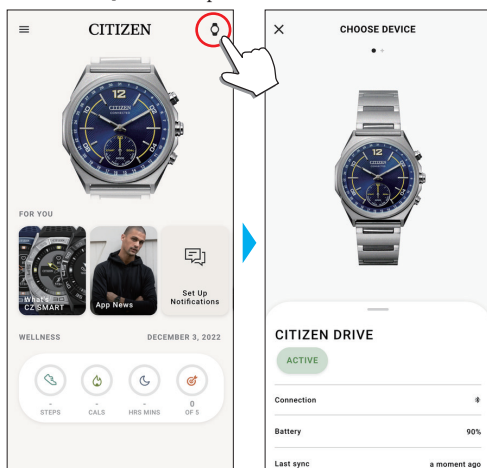

3 Swipe left or right on the screen to display the connected watch and swipe up the tab on the bottom of the screen.

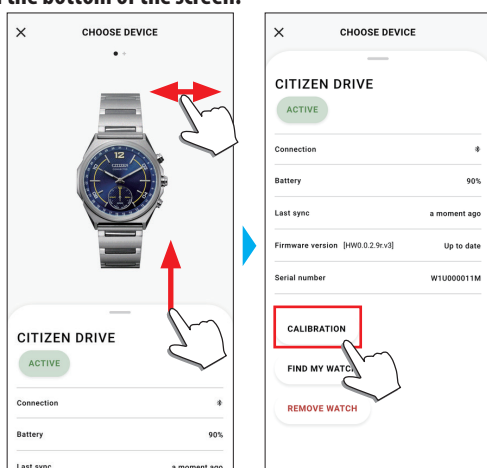

4 Tap [CALIBRATION].

The reference position of the hour hand becomes adjustable.

Tap here when finishing adjustment of reference position of all hands.

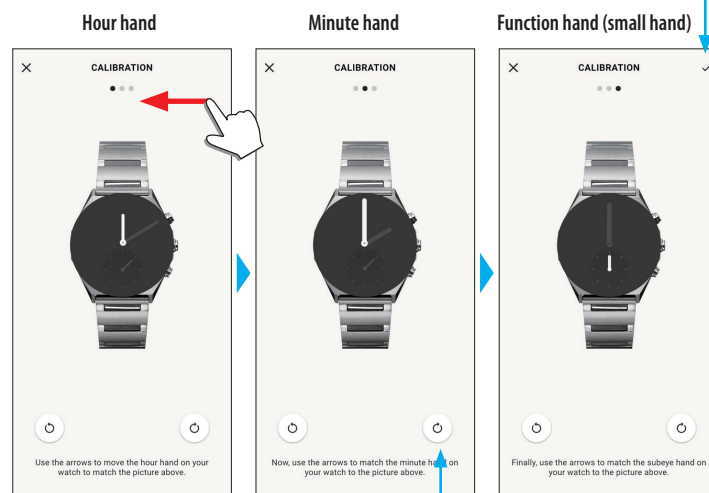

Tap the buttons to adjust the reference position of each hand.

5 Correct the reference position of watch hands following instructions on the screen.

- Use the buttons below the image of the watch to move the watch hands.

6 Swipe left after finishing adjustment of the hour hand.

The reference position of the minute hand becomes adjustable.

7 Adjust the reference position of the minute hand and function hand (small hand) through the same steps.

8 Tap the check icon (✓) on the upper right of the screen to finish the procedure.

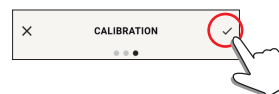

- The check icon (✓) appears on the screen of adjustment of reference position of the function hand (small hand).

Battery replacement

This watch tells you battery replacement period when battery voltage becomes low by stopping all the hands at the 6 o'clock position.

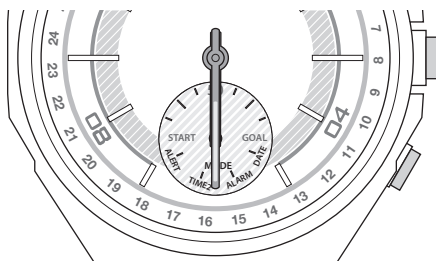

- The indication is canceled by pressing button but early replacement of the battery is recommended.
- You can check battery remaining of the watch on the [CHOOSE DEVICE] screen of the dedicated app.

■ When replacing the battery

1 Turn the case back of the watch counterclockwise using a coin or something similar.

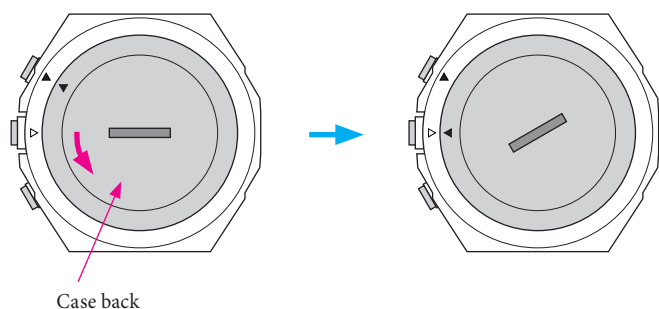

Case back

- Turn the case back until the engraving on it (▲) aligns with △ on the case edge.

2 Turn the watch over to remove the battery.

3 Put a new battery in to the watch.

- Set the battery so that its plus (+) will come to the top.

4 Confirm that the rubber packing for waterproofing is set at the correct position.

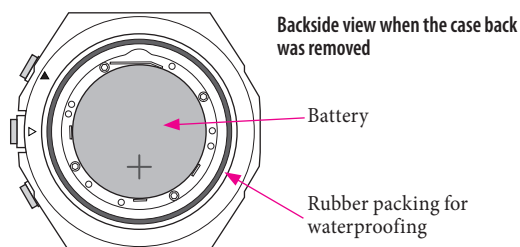

5 Put on the case back confirming that the engraving on it (▲) aligns with △ on the case edge and turn the case back clockwise.

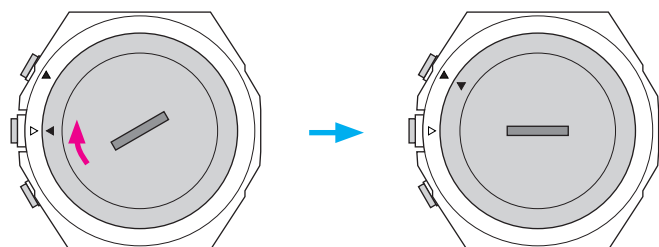

- Turn the case back until the engraving on it (▲) aligns with ▲ on the case edge.
- Take care so that any foreign matter such as thread waste is not caught between the case back and the case.
- Turn the case back securely until the slot become straightly horizontal.
- After replacing the battery, start the dedicated app and synchronize the watch and the smartphone.

Troubleshooting

Symptom	Remedies
Pairing	
Cannot execute pairing, synchronization or update.	Set the watch near the smartphone.
	Check the settings of Bluetooth and positional information the smartphone and the dedicated app.
	Cancel existing pairing and execute pairing again if you had executed pairing.
	If all the hands of the watch sometimes stop at the 6 o'clock position, replace the battery.
All the hands of the watch stop at the 6 o'clock position.	Replace the battery of the watch.
I want to Cancel existing pairing.	Choose the watch you currently use on the [CHOOSE DEVICE] screen of the dedicated app, swipe up the tab on the bottom of the screen, then tap [REMOVE WATCH] to cancel pairing with it. After that, remove the name of the watch you currently use on the Bluetooth setting of your smartphone.
Time/calendar	
Cannot adjust time/calendar.	You cannot adjust time and calendar manually on this watch. The watch follows the time and calendar of your smartphone by connecting with it through the dedicated app.
Time/calendar is incorrect.	Check time and calendar on your smartphone and start up the dedicated app to synchronize it with the watch.
	Correct the reference position of the hands of the watch. Choose the watch you currently use on the [CHOOSE DEVICE] screen of the dedicated app, swipe up the tab on the bottom of the screen, then tap [CALIBRATION].
Activity monitor	
My sleep is not recorded on the activity monitor.	It is automatically recorded when you put on the watch while you are sleeping.
I want to change my account name.	Tap your account name on the side menu on the dedicated app.
I want to change the values of my height and weight.	Tap [Wellness] then [Profile] on the side menu of the dedicated app.
I want to change the units for length and temperature on the dedicated app.	Tap [Preferred Units] on the [MY PREFERENCES] screen of the dedicated app.
Data of the activity monitor is not sent to the dedicated app.	Replace the battery of the watch when battery remaining of the watch is small.
	Put the watch on your wrist correctly.
Notification/alarm	
No notifications come.	Check the setting of notification on the [MY PREFERENCES] screen of the dedicated app.
	Check whether the switch of [Do Not Disturb] is deactivated on the [MY PREFERENCES] screen of the dedicated app.
Alarm does not work.	Check the settings of alarm on/off, alarm time and alarm repetition on the [ALARMS] screen from the [MY PREFERENCES] screen of the dedicated app.
Others	
I want to check battery remaining.	Choose the watch you currently use on the [CHOOSE DEVICE] screen of the dedicated app, swipe up the tab on the bottom of the screen, then check the value of [Battery].
Cannot make out what the function hand (small hand) is indicating.	The function hand (small hand) of this watch indicates activity achievement by pointing the upper half of the small dial; it indicates the current mode of the watch by pointing the lower half.
The hands stop.	When all the hands of the watch stop at the 6 o'clock position, battery remaining of the watch is not enough. Replace the battery soon.

- If any of the methods above does not solve your problem, remove the battery from your watch and set it again.

Bluetooth® wireless technology

Regulatory concerning to Bluetooth (Areas where Bluetooth is available)

Use of the Bluetooth communication technology is not legally permitted in some countries or regions.

- Using this watch in a country where it is not permitted may be punished under its law.
- Communication using Bluetooth may be monitored intentionally or accidentally. Do not use this watch for important communication or any communication involving human lives.

For details of Bluetooth, see the following items.

www.citizenwatch-global.com/support/yf05/index.html



Water resistance

WARNING Water resistance

- Refer to the watch dial and/or the case back for the indication of the water resistance of your watch. The following chart provides examples of use for reference to ensure that your watch is used properly. (The unit "1bar" is roughly equal to 1 atmosphere.)
- WATER RESIST(ANT) x×bar may also be indicated as W.R.x×bar.
- Non-water resistant models are not designed to come into contact with any moisture. Take care not to expose a watch with this rating to any type of moisture.
- Water resistance for daily use (to 3 atmospheres) means the watch is water resistant for occasional accidental splashing.
- Upgraded water-resistance for daily use (to 5 atmospheres) means that the watch may be worn while swimming, but is not to be worn while skin diving or scuba diving.
- Upgraded water-resistance for daily use (to 10/20 atmospheres) means that the watch may be worn while skin diving, but not while scuba diving or saturated diving using helium gas.

Name	Indication	Specification	Water-related use					
	Dial or Case back		Minor exposure to water (washing face, rain, etc.)	Swimming and general washing work	Skin diving, marine sports	Scuba diving using an air tank	Saturation diving using helium gas	Operate the crown or button when the watch is wet
Non-water resistant	—	Non-water resistant	NO	NO	NO	NO	NO	NO
Everyday-use water resistant watch	WATER RESIST	Water-resistant to 3 atmospheres	OK	NO	NO	NO	NO	NO
Upgraded everyday use water resistant watch	W. R. 5 bar	Water-resistant to 5 atmospheres	OK	OK	NO	NO	NO	NO
	W. R. 10 bar W. R. 20 bar	Water-resistant to 10 and 20 atmospheres	OK	OK	OK	NO	NO	NO

Precautionary items and usage limitations

CAUTION Battery replacement

- Do not recharge the used battery.
- Do not throw the used battery into the fire.
- Do not ingest battery – Chemical Burn Hazard.
- This product contains a coin/button cell battery. If the coin/button cell battery is swallowed, it can cause severe internal burns in just 2 hours and can lead to death.
- Keep new and used batteries away from children.
- If the battery compartment does not close securely, stop using the product and keep it away from children.
- If you think batteries might have been swallowed or placed inside any part of the body, seek immediate medical attention.
- Do not disassemble, customize or heat the battery. It may result in a serious accident.
- Leaving a used battery in the watch may damage it through leakage and result in malfunction. Replace the battery soon.
- When replacing the battery, always make sure to use the designated one.
- Do not replace the battery with any other than the specified one. If it is replaced with an incorrect battery, it may explode or the watch may have malfunction.

CAUTION To Avoid Injury

- Be particularly careful when wearing your watch while holding a small child, to avoid injury.
- Be particularly careful when engaged in strenuous exercise or work, to avoid injury to yourself and others.
- Do NOT wear your watch while in a sauna or other location where your watch may become excessively hot, since there is the risk of burns.
- Be careful when putting on and taking off your watch, since there is a risk of damaging your fingernails, depending on the manner in which the band is fastened.

CAUTION Precautions

- Always use the watch with the crown pushed in (normal position). If the crown is of the screw lock-type, make sure it is securely locked.
- Do not operate (use the crown and/or buttons) the watch when it is wet. Water may enter the watch causing damage to vital components.
- If water enters the watch or the watch fogs up and does not clear up even after a long time, consult your dealer or an authorized service center for inspection and/or repair.
- Even if your watch has a high level of water resistance, please be careful of the following.
 - If your watch is immersed in sea water, rinse thoroughly with fresh water and wipe with a dry cloth.
 - Do not pour water from a tap directly onto your watch.
 - Take off your watch before taking a bath.
- If seawater enters the watch, place the watch in a box or plastic bag and immediately take it in for repair. Otherwise, pressure inside the watch will increase, and parts (crystal, crown, push button, etc.) may come off.

CAUTION When Wearing Your Watch

<Band>

- Leather bands and rubber (urethane) bands will deteriorate over time due to perspiration or dirt. In addition, they are made of natural material and will be worn, deformed and discolored over time. It is recommended to replace the band periodically.
- The durability of a leather band may be affected when wet (fading, peeling of adhesive), owing to the properties of the material. Moreover, wet leather may cause a rash.
- Do not stain a leather band with substances containing volatile materials, bleach, alcohol (including cosmetics). Discoloration and premature aging may be occurred. Ultraviolet light such as direct sunlight may cause discoloration or deformation.
- It is recommended to take off the watch if it gets wet, even if the watch itself is water-resistant.
- Do not wear the band too tightly. Try to leave enough space between the band and your skin to allow adequate ventilation.
- The rubber (urethane) band may be stained by dyes or soil present in or on clothing or other accessories. Since these stains may not be removable, caution is required when wearing your watch with items that tend to easily transfer color (articles of clothing, purses, etc.). In addition, the band may be deteriorated by solvents or moisture in the air. Replace with a new one when it has lost elasticity or become cracked.
- Please request adjustment or repair of the band in the following cases:
 - You notice an abnormality with the band due to corrosion.
 - The pin of the band is protruding.
- We recommend seeking the assistance of an experienced watch technician for sizing of your watch. If adjustment is not done correctly, the bracelet may unexpectedly become detached leading to loss of your watch or injury (excluding products containing the band adjustment tool). Consult an authorized service center. Other shops may charge for, or may not provide, the service.

<Temperature>

- The watch may stop or the function of the watch may be impaired in extremely high or low temperature.
- Do not use or store the watch in an environment with excessive heat or cold, or with conditions which may cause battery leakage, heating, explosion or flaming.

<Magnetism>

- Analog quartz watches are powered by a step motor that uses a magnet. Subjecting the watch to strong magnetism from the outside can cause the motor to operate improperly and prevent the watch from keeping time accurately.

Do not allow the watch to come into close proximity to magnetic health devices (magnetic necklaces, magnetic elastic bands, etc.) or the magnets used in the latches of refrigerator doors, clasps used in handbags, the speaker of a cell phone, electromagnetic cooking devices and so on.

<Strong Shock>

- Avoid dropping the watch or subjecting it to other strong impact. It may cause malfunctions and/or performance deterioration as well as damage to the case and bracelet.

<Static Electricity>

- The integrated circuits (IC) used in quartz watches are sensitive to static electricity. Please note the watch may operate erratically or not at all if exposed to intense static electricity.

<Chemicals, Corrosive Gasses and Mercury>

- Do not use the watch in environment with chemicals or corrosive gasses. If paint thinner, benzene or other solvents or products containing these solvents (including gasoline, nail-polish remover, cresol, bathroom cleaners and adhesives, water repellent, etc.) are allowed to come into contact with the watch, they may discolor, dissolve or crack the materials. Be careful when handling these chemicals. Contact with mercury such as that used in thermometers may also cause discoloration of the band and case.

<Protective Stickers>

- Be sure to remove any protective stickers that may be on your watch (case back, band, clasp, etc.). Otherwise, perspiration or moisture may enter the gaps between the protective stickers and the parts, which may result in a skin rash and/or corrosion of the metal parts.

⚠ CAUTION Always Keep Your Watch Clean

- Rotate the crown while it is pressed in fully and press the buttons periodically so they do not become stuck due to accumulations of foreign matter.
- The case and band of the watch come into direct contact with the skin. Corrosion of the metal or accumulated foreign matter may result in black residue coming from the bracelet when exposed to moisture or perspiration unnoticed soiling such as that caused by perspiration. Be sure to keep your watch clean at all times.
- The case and band of the watch come into direct contact with the skin. In rare circumstances, accumulated dirt, foreign matter may cause irritation with the skin. If you think there is something wrong, discontinue wearing the watch immediately and consult your physician.
In the case of accumulation of sweat or dirt on a metal band or case, clean thoroughly using a brush and neutral detergent. In the case of a leather or rubber (urethane) band, wipe clean using a dry cloth.
- Leather bands may become discolored by perspiration or dirt. Always keep your leather band clean by wiping with a dry cloth.

Caring for Your Watch

- Wipe any dirt or moisture such as perspiration from the case and crystal with a soft cloth.
- For a metallic, plastic or rubber (urethane) watchband, wash any dirt off with water. Remove the small amounts of dirt trapped between the crevices of the metallic band with a soft brush.
- For a leather band, wipe off dirt using a dry cloth.
- If you will not be using your watch for an extended period of time, carefully wipe off any perspiration, dirt or moisture and store in a proper location, avoiding locations subject to excessively high or low temperatures and high humidity.

When Luminous Paint is used for your watch

The paint on the dial and hands helps you with reading the time in a dark place. The luminous paint stores light (daylight or artificial light) and glows in a dark place.

It is free from any radioactive substance or any other material harmful to a human body or environment.

- The light emission gradually becomes weaker as time passes.
- The duration of the light ("glow") will vary depending on the brightness, types of and distance from a light source, exposure time, and the amount of the paint.
- The paint may not glow and/or may dissipate quickly if exposure to light was not sufficient.

Specifications

Model	YF05	
Type	Analog quartz watch	
Display functions	Time	Hour, minute
Duration	About 1 year (It may get shorter depending on conditions of use.)	
Battery	Primary cell (manganese dioxide lithium button cell CR2430), 1pc.	
Additional functions	<ul style="list-style-type: none"> • Battery life notice function • Alarm function (vibration) • Vibration function (setting through the dedicated app) 	

The following conditions are supposed in the table below when measuring "Duration".

Connection with the smartphone	19 hours/day
Automatic reconnection	14 times/day
Data synchronization	20 times/day
Notification	Twice/day

Specifications and contents are subject to change without prior notice.